

Toulouse

Wandaußenmaß: 380 x 250 cm

Bohlenstärke: 28 mm



Kontrolliert durch:





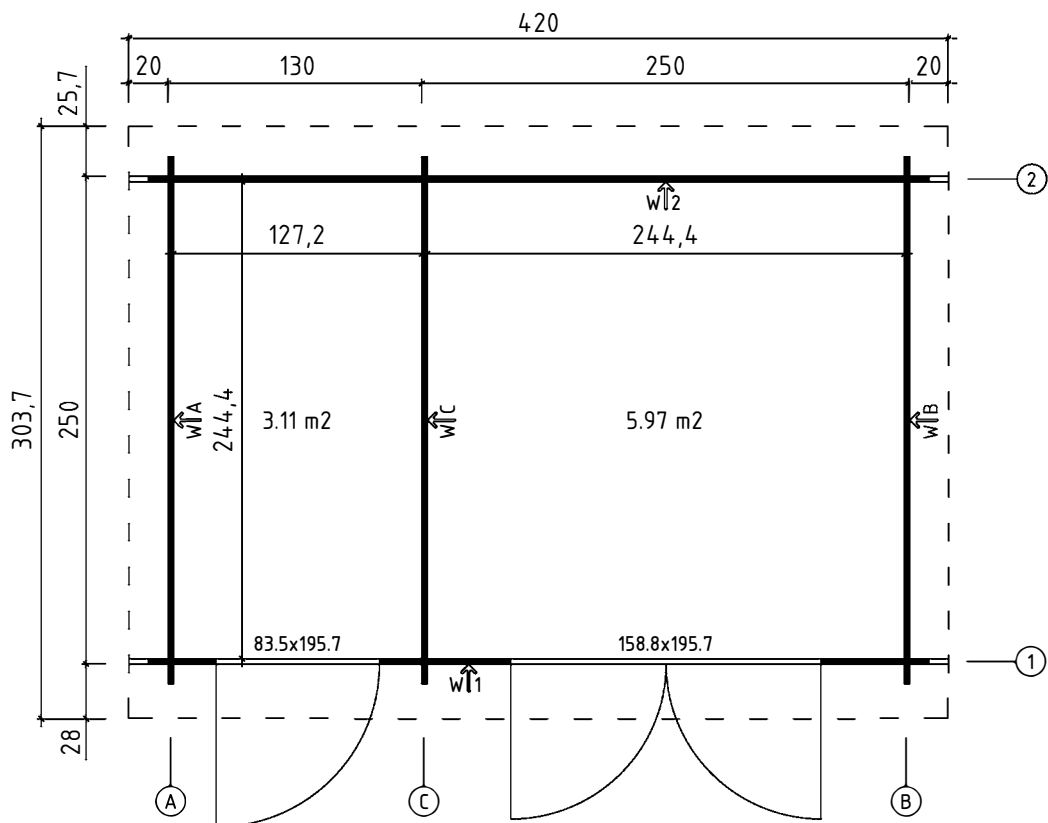
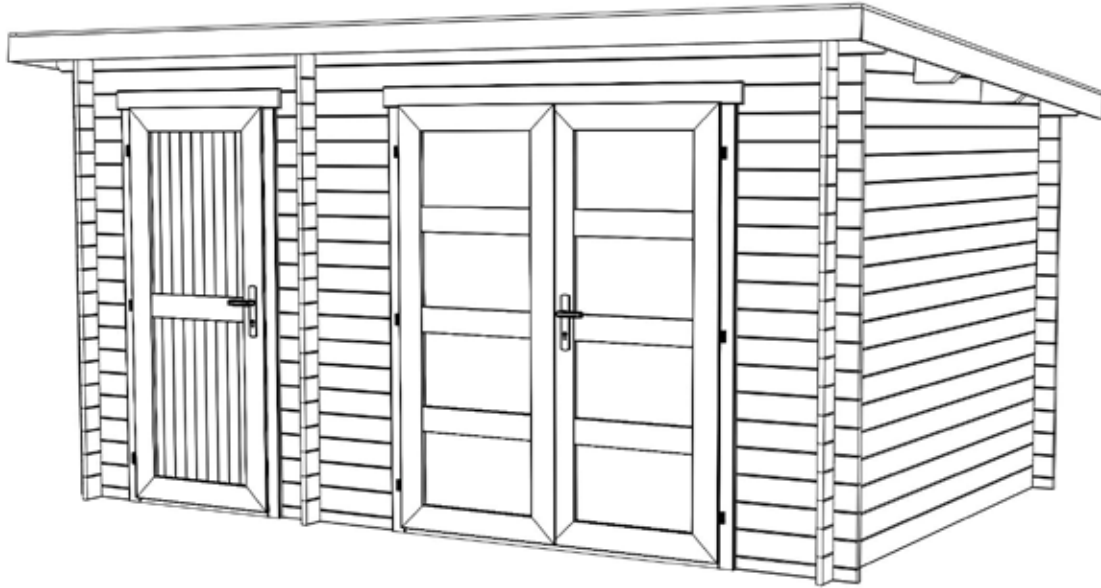







Achtung: Alle angegebenen Maße sind ca.-Maße!

3D-Ansicht und Grundriss Toulouse

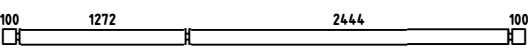
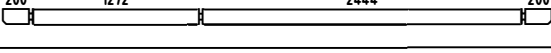
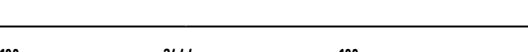
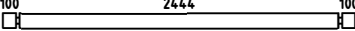
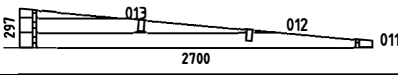
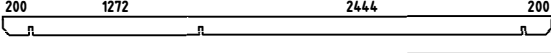
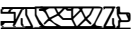

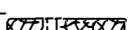

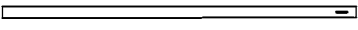
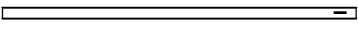
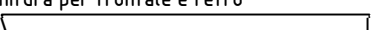

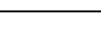



Teilleiste 1

Toulouse

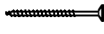
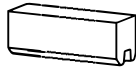
Pos		Q	P (mm)	L (mm)
001		1	28x57	342
002		1	28x57	665
003		1	28x57	550
004		17	28x114	342
005		17	28x114	665
006		17	28x114	550
007		17	28x114	4000
008		2	28x114	4200
009		1	28x57	4000
010		51	28x114	2700
WA-1 WB-1 WC-1		1 1 1		
A-PR1	Roof beam - Dachbalken - Panne de toit - Perlina del tetto - Gordingen / dakbalk - Abipärliid 	2	44x140	4200
DB	Roof boards - Dachbretter - Voliges - Perlina per tetto - Dakhout - Katuselaud 	47	90x15	3050
RFF	Roofing felt fillet - Dachpappenteiste - Baguette de fixation du feutre bitumeux - Asse per fissaggio guaina bituminosa - Afdeklijst asfaltpapier - Katusepapiiist 	2	15x45	3115
RFF2	Roofing felt fillet - Dachpappenteiste - Baguette de fixation du feutre bitumeux - Asse per fissaggio guaina bituminosa - Afdeklijst asfaltpapier - Katusepapiiist 	1	15x45	4140
TB	Fascia board - Traufbrett - Bandeau de toit - Finitura lati tetto - Gevellijst - Räästalaud 	1	15x120	4230
DRV	Roof edge reinforcement - Dachrandverstärkung - Corniere de renfort de bord de toit - Rinforzo x tetto - Dakrand versterking - Räästatugevdus 	1	15x45	4200
DRV2	Roof edge reinforcement - Dachrandverstärkung - Corniere de renfort de bord de toit - Rinforzo x tetto - Dakrand versterking - Räästatugevdus 	1	28x34	4200
KFS-1	Storm protection - Sturmleiste - Latte anti-tempete - Protezione anti vento - Stormverankering / beveiliging - Tormikinnitus 	2	22x45	2050
KFS-2	Storm protection - Sturmleiste - Latte anti-tempete - Protezione anti vento - Stormverankering / beveiliging - Tormikinnitus 	2	22x45	2500
HS9	Gable moulding - Giebelleiste - Planche de rive - Finitura per frontale e retro del tetto - Gevellijst - Viilulaud 	2	15x120	3100
HS9	Screw for gable moulding - Schrauben für giebelleiste - Vis pour fixation planche de rive - Vite per fissare finiture davanti e dietro del tetto - Schroef voor gevellijst - Krugi viilulauale 	16	3.5x50	
HS4	Screw for roof edge reinforcement - Schrauben für dachrandverstärkung - Vis pour fixation corniere renfort de bord de toit - Viti x rinforzo bordo tetto - Schroef voor dakrand versterking - Krugi räästatugevdusele 	10	3x30	



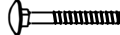



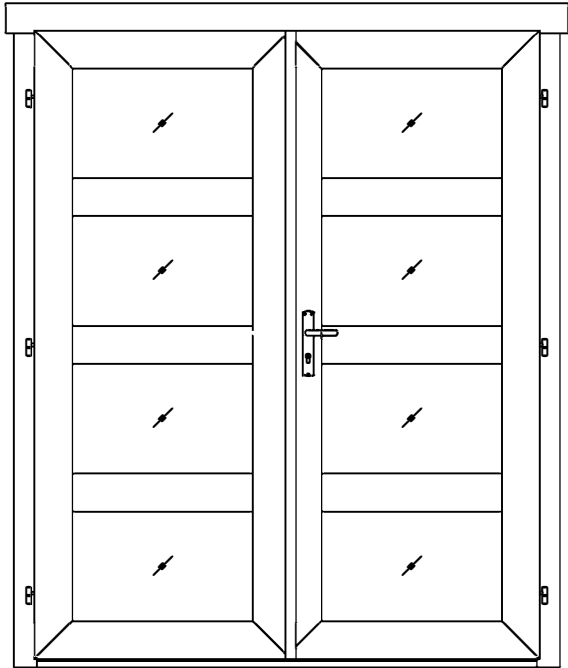
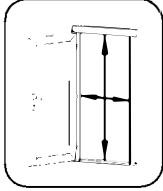
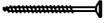

Teileliste 2

Toulouse

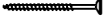
Pos		Q	P (mm)	L (mm)
HS12	Screw for fascia boards - Schrauben für traufbretter - Vis pour fixation bandeau de toit - Viti x striscia del tetto - Schroef voor gevellijst - Krugi räästalaualale 	10	4x40	
HS12	Screw for roof edge reinforcement - Schrauben für dachrandverstärkung - Vis pour fixation corniere renfort de bord de toit - Viti x rinforzo bordo tetto - Schroef voor dakrand versterking - Krugi räästatugevusele 	10	4x40	
HS18	Screw for roof beams - Schrauben für dachbalken - Vis pour fixation pannes de toit - Viti per perline del tetto - Schroef voor gordingen / dakbalken - Krugi pärlinitele 	6	5x120	
HS18	Screw for gable - Schrauben für giebel - Vis pour fixation des pignons - Viti per timpano - Schroef voor gevelpunt - Krugi viilude kinnitamiseks 	6	5x120	
SH28	Hammer block - Schlagholz - Calle de frappe - Blocco di legno da usare come cuscinetto quando si usa il martello - Slagklos - Löögiklots 	1		
SFS	Nut for storm protection - Schraubenmutter für sturmleiste - Ecrou pour latte anti-tempete - Dado x asta protezione vento - Moer voor stormverankering - Mutter tormikinnitusele 	8	D6	
NF4	Zn nail for roof - Zn nägel für dachbretter - Pointe pour fixation voliges de toit - Chiodi x perline tetto - Spijker(nagel) voor dakhout - Nael katuselauale 	201	2x50	
NF5	Zn nail for roofing felt fillet - Zn nägel für dachpappenteiste - Pointe pour baguette de fixation feutre bitumeux - Chiodi x carta bituminosa x tetto - Spijker(nagel) voor asfaltpapier afdekljst - Papillistunael 	25	2x40	
BFS	Bolt for storm protection - Bolzen für sturmleiste - Boulon pour latte anti-tempete - Bullone x asta protezione vento - Bout voor stormankerlat - Puidupolt tormikinnitusele 	8	6x60	
DFS	Washer for storm protection - Dichtscheibe für sturmleiste - Rondelle pour latte anti-tempete - Rondella x asta protezione vento - Afdichtring voor storm strip - Seib tormikinnitusele 	8	D6	
	Door - Tür - Porte - Porte - Deur - Uks	1588x1957 TUK.4.020.MVP.MM MGC	1	
	Door - Tür - Porte - Porte - Deur - Uks	835x1957 UL.2.100.IVV.MM TC	1	





Teileliste 3

Toulouse

		Q	P (mm)	L (mm)
	<p>Glass size – Glasgröße – Taille de la vitre – Misura del vetro – Glas afmeting – Klaasi mõõt: 561x348 mm</p>   <p>1488x1875 mm</p>			
HS4	<p>Screw for door fillet – Schraube zur Befestigung türleiste – Vis pour fixation baguette d'arrêt de porte – Viti per massellino della porta – Schroef voor deurtijst – Krugi ukse kokkuvaltssiliistule</p> 	5	3x30	
HS16	<p>Screw for door jamb – Schraube für Türrahmen – Vis de fixation partie haute avec montants du cadre de porte – Viti x fissaggio montanti porte – Schroef voor deurkozijn – Krugi ukse lengile</p> 	4	5x90	
HS25	<p>Screw for doorstep – Schrauben für swelle – Vis pour fixation barre de seuil – Vite per soglia della porta – Schroef voor deurdorpel – Krugi lävepakule</p> 	3	4.5x65	
TL4	<p>Door handle fittings – Türgriff – Poignée de porte – Maniglie – Deurhendel klink – Ukse käepide</p> 	1		
TL5	<p>Set of door lock covers – Schlossblenden – Set de garnitures de porte – Copertura serrature – Slot sluitplaat set – Ukse lukuplaat</p> 	1		
	<p>Cylinder lock – Zylinderschloss – Barillet de porte – Serratura – Cylinder slot – Ukse lukusüdamik</p> 	1	30x35	
	<p>Male bolt hinge for door – Türband – Partie male de paumelle de porte – Cerniera anube x porta – Scharnier bout – Ukse polthing isane</p> 	6		
	<p>Striker for barrel bolt – Hülse für Grendelriegel – Gache au sol du targette – Boccola per fermo della porta – Huls voor vergrendelingschuif – Vasturaud ukse servariivile</p> 	2		

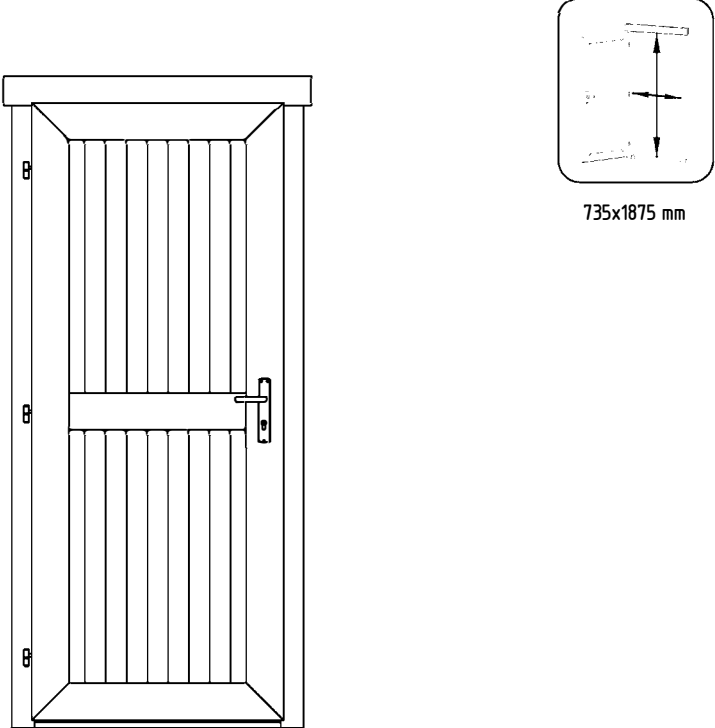
Teileliste 4

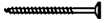
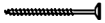
Toulouse

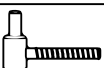
Pos		Q	P (mm)	L (mm)
				
HS25	Screw for doorstep - Schrauben für swelle - Vis pour fixation barre de seuil - Vite per soglia della porta - Schroef voor deurdorpetel - Kruvi lävepakule 	2	4.5x65	
HS16	Screw for door jamb - Schraube für türrahmen - Vis de fixation partie haute avec montants du cadre de porte - Viti x fissaggio montanti porte - Schroef voor deurkozijn - Kruvi ukse lengile 	4	5x90	
TL4	Door handle fittings - Türgriff - Poignee de porte - Maniglie - Deurhendel / klink - Ukse käepide 	1		
TL5	Set of door lock covers - Schlossblenden - Set de garnitures de porte - Copertura serrature - Slot sluitplaat set - Ukse lukuplaat 	1		
	Cylinder lock - Zylinderschloss - Barillet de porte - Serratura - Cylinder slot - Ukse lukusüdamik 	1	30x35	
	Male bolt hinge for door - Türband - Partie male de paumelle de porte - Cerniera anube x porta - Scharnier bout - Ukse polthing isane 	3		

Wandplan A, B und C Toulouse

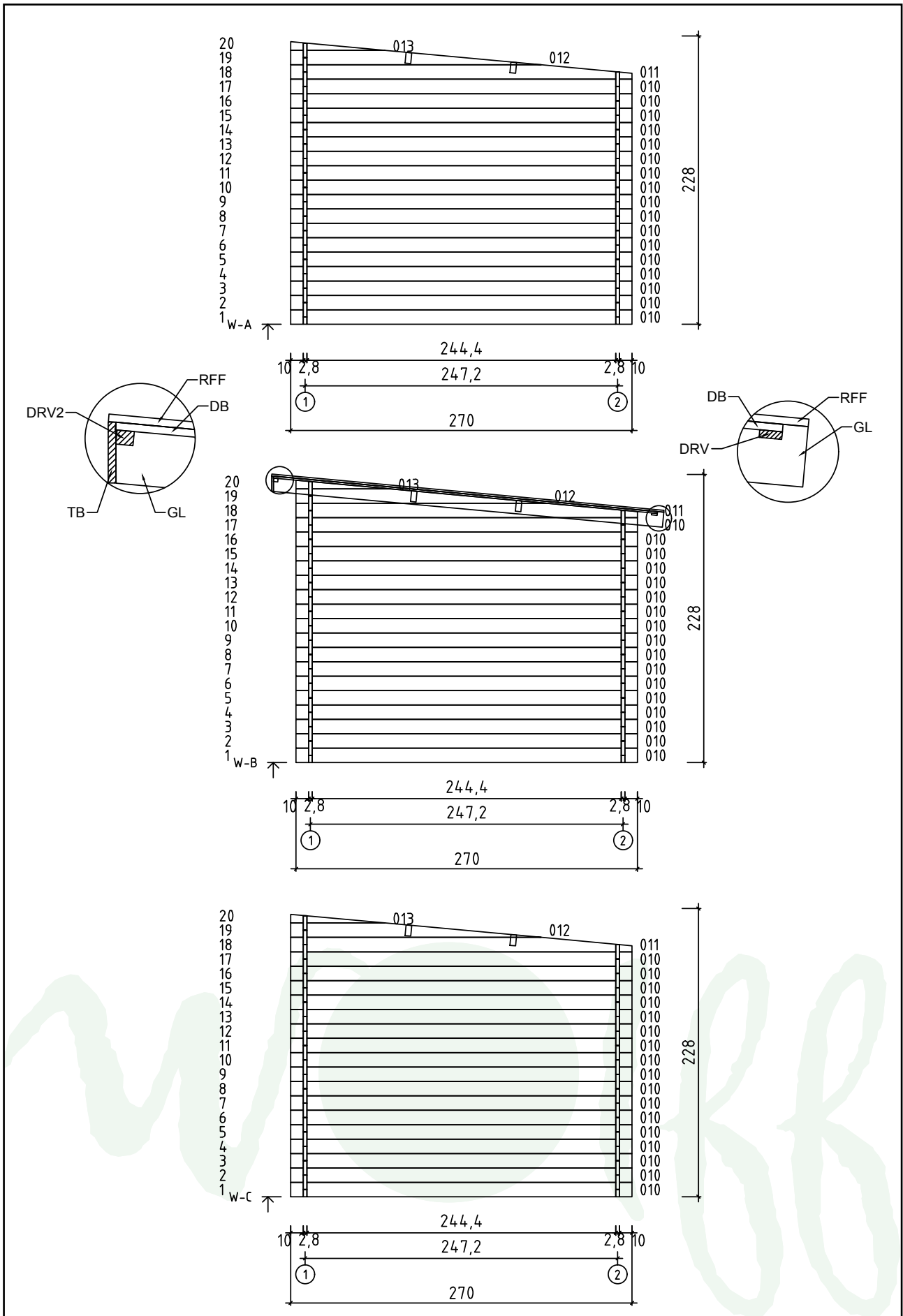

Wandplan 1 und 2 Toulouse

